

DMC Operation Manual

PRODUCT INFORMATION BULLETIN #3365
DIGITAL MOTOR CONTROL PLATTER SYSTEMS
For Serial Number 28640996 and After

Record Platter System Identification Numbers Here:

Model # _____ Serial # _____

Table of Contents

Program Run	2
Take-up and Control Plate DMC Calibration	3
Motor Height Adjustment	4
Feed Castor Switch Adjustment	4
Failsafe Switch Adjustment	4
Take-up and Control Plate DMC LED Error Indication	5
Power Supply DMC Removal	5
Control Plate DMC Removal	5
Trouble Shooting	6
Maintenance	7
Threading Diagrams	8
Wire Schematics	10

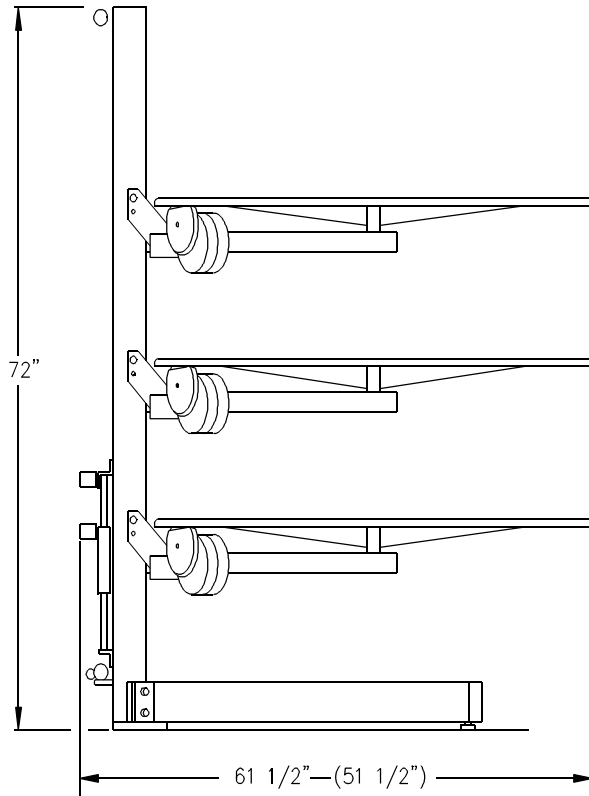

LEFT SIDE

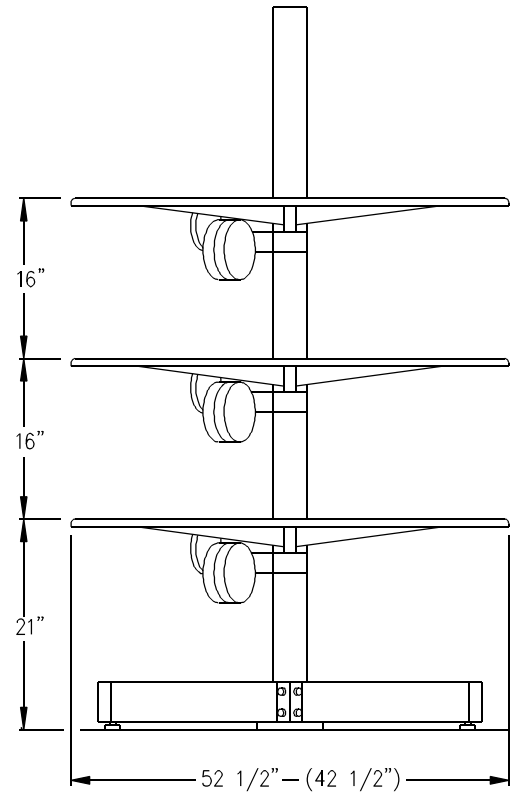

FRONT

DMC PLATTER
52" (42") DIA. DISKS
WEIGHT 400 POUNDS

POWER SOURCE

The AP/DMC (Digital Motor Control) platter system is a dual voltage system 100/300 VAC 50/60 Hz. 6 AMP or 210/240 VAC 50/60 Hz. 3 AMP. The power supply can be converted from 120 VAC to 240 VAC by changing a jumper plug in the power supplies, and re-fusing for the appropriate voltages. The fuse chart is on page 1 of 3 of the DMC wire schematic. The make-up table provides 0/120 VAC to drive the platters for Make-up.

OVER VIEW

The AP/DMC platter system uses an unregulated 35 vdc tri-modular power supply. Each drive motor is controlled by a software driven digital motor control (DMC). There is one digital motor control located in the power supply enclosure using inputs from the take-up assembly to control the speed of the Rewind platter. This Take-up DMC is capable of driving the rewind platter from zero to 150 feet/min. at the center ring diameter. The Take-up DMC is automatically selected by threading film through the feed castor onto the platter. When the feed castor is down, that platter is in Pay-out and the control plate DMC will control the motor. The Failsafe circuit will shut down the Rewind platter only. The Pay-out platter remains powered for thread up and Inter Locking two platter systems.

INSTALLATION

After the platter system is uncrated, platters installed and platter to projector film path adjusted, and prior to running film, the Take-up DMC and each Control Plate DMC should be calibrated. (see page 3)

PROGRAM RUN

This section explains how to operate the Platter system after a program is made up. Make-up and break down of a program is explained in the Make-up Table operation manual.

In PROGRAM RUN, you feed film to the projector from one platter, and rewind the returning film onto an empty platter. The platter that is feeding film is the PAYOUT platter, and the empty platter that the film is returning to is the REWIND platter. The threading path for a 3-deck Platter System is shown on pages 7 and 8.

- 1) Place the suction cup brackets, evenly spaced, on the outside of the film to hold it in place. Pull the knob on the center ring and collapse the ring. Gently lift the ring out of the center of the film, expand the ring and place it in the center of the selected REWIND platter. Make sure the center ring is locked in the expanded position.
- 2) Take the leader from the center of the PAYOUT platter and thread it through the control plate, as shown. The Pay-out platter is powered so when the control plate arm is moved during threading the platter will turn.
- 3) After following the appropriate diagrams for threading, hook the film into the center ring on the REWIND platter. Be sure the angle of twist on the film is correct.

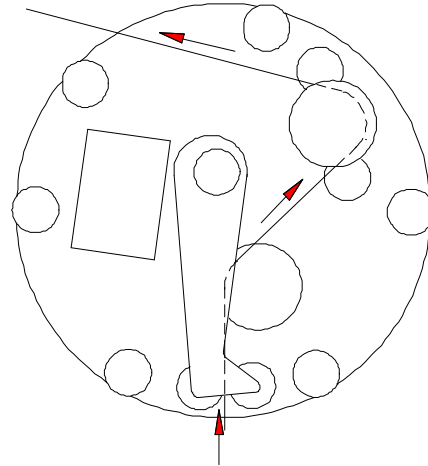

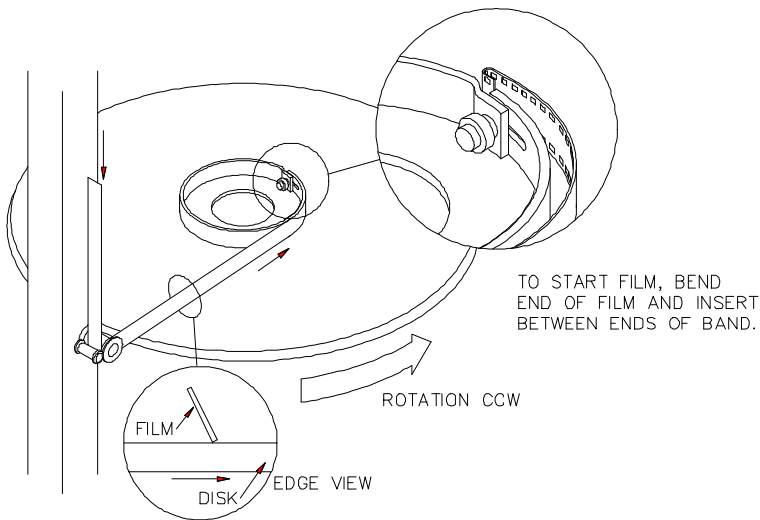

- 4) Rotate the REWIND platter by hand until the take-up carriage is at the top of its travel.
CAUTION: As soon as the take-up carriage comes off the bottom of its travel the rewind platter will be under power and will have to be slowed down as the carriage nears the top of its travel.
- 5) Double check your film path. Turn the projector on and the platter will feed and rewind the film.

Note: The make-up switches, located below each feed castor on the side of the column, are wired to override the PAYOUT and REWIND functions. During PROGRAM RUN these switches must be in the "0" (off) position.

TAKE-UP DMC CALIBRATION

Note: Power Supply cover must be in place before calibration.
LED's can be viewed through the take-up linkage rod slot.

- 1) Turn power off. (wait 30 seconds)
- 2) Press and hold the calibration toggle switch.
- 3) Turn power on with the calibration toggle switch engaged. (the yellow LED is ON)
- 4) Release the Calibration switch. (the yellow LED remains ON)
- 5) Raise the Take-Up carriage all the way to the top.
- 6) Press and hold the calibration toggle switch. (the yellow LED will turn OFF)
- 7) Lower the carriage all the way to the bottom.
- 8) Release the calibration toggle switch.
(the red LED should blink off once, and then the yellow LED should start to blink)
- 9) Calibration is complete.

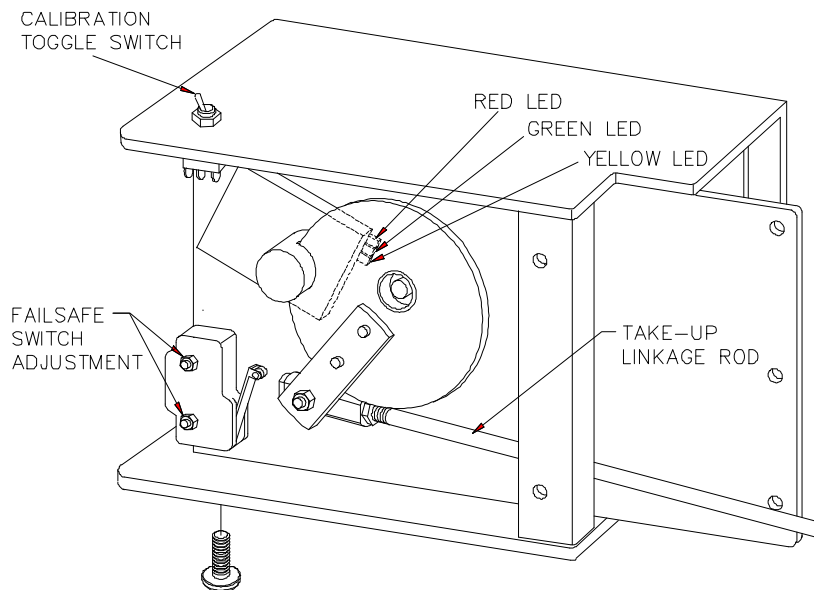

CONTROL PLATE DMC CALIBRATION

- 1) Disengage the drive motor.
- 2) Unplug the control plate.
- 3) Press and hold the calibration switch.
- 4) Plug in the control plate with the calibration switch engaged. (the yellow LED is ON)
- 5) Release the Calibration switch. (the yellow LED remains ON)
- 6) Move the control arm all the way CCW.
- 7) Press and hold the calibration switch. (the yellow LED will turn OFF)
- 8) Move the control arm all the way CW.
- 9) Release the calibration switch. (the red LED should blink off once, and then the yellow LED should start to blink)
- 10) Calibration is complete, engage the drive motor.

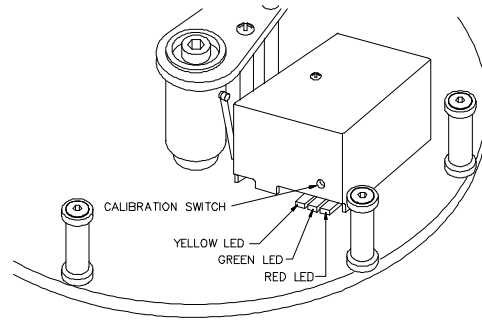

MOTOR HEIGHT ADJUSTMENT

- 1) Turn power off, disengage the drive motor and adjust drive wheel 1/4" to 3/8" from bottom of the platter by loosening the two hex screws that hold the drive motor to the platter arm.

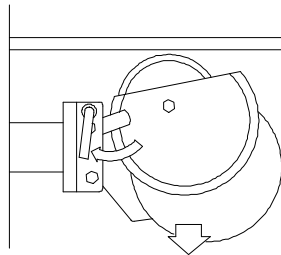

DISENGAGED

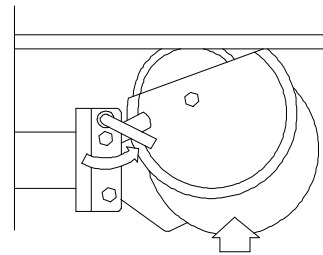

ENGAGED

FEED CASTOR SWITCH ADJUSTMENT

CAUTION: TO AVOID ELECTRICAL SHOCK HAZARD turn the power switch to OFF and unplug the power supply cord before making any feed castor switch adjustments.

- 1) Turn power ON, raise the take-up carriage approximately half way, and raise the feed castor to it's upper limit. The platter should begin to run. Lower the feed castor and the platter should stop half way between the upper and lower limit of the feed castor. When the feed castor is at it's lower limit the control plate DMC controls the platter.
- 2) The feed castor switch is set correctly if the switch activates (audible click) when the feed castor is half way between it's upper and lower limit. If adjustment is required, the feed castor must be removed from the column.

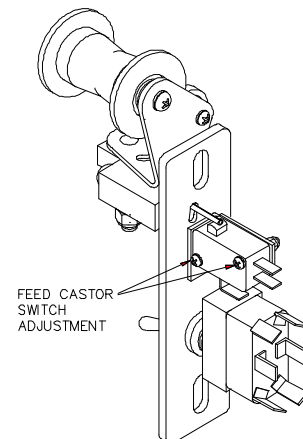

FAILSAFE SWITCH ADJUSTMENT

CAUTION: TO AVOID ELECTRICAL SHOCK HAZARD turn the power switch to OFF and unplug the power supply cord before making any failsafe switch adjustments.

- 1) Raise and lower the take-up carriage by hand. The FAILSAFE SWITCH should activate (audible click) between 1/2" and 3/4" from the bottom of it's travel.
- 2) Loosen the two hex nuts securing the FAILSAFE SWITCH and reposition it until the condition described in step (1) is achieved. Retighten the hex nuts.

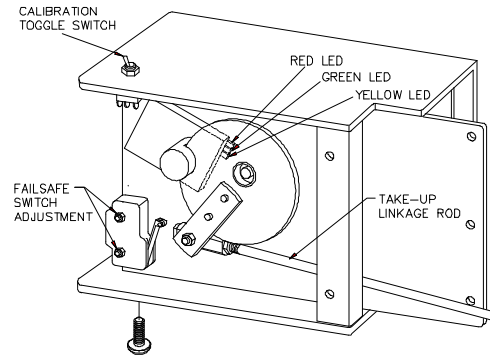

TAKE-UP and CONTROL PLATE DMC ERROR INDICATION

DMC Red LED

(ON) Power is supplied and computer is working properly.
(OFF) Power loss, or DMC is faulty.
(BLINKING) DMC is in a "watch dog" reset. (computer error)

DMC Green LED

(ON) Power on.
This LED is not used at this time.

DMC Yellow LED

(ON) DMC was powered up with the calibration switch on.
(OFF) Control plate arm position sensor is faulty, or is in step #7 of calibration mode.
(BLINKING) Control plate arm position sensor functioning normal.
(BLINKING FAST) DMC detecting a motor short condition.

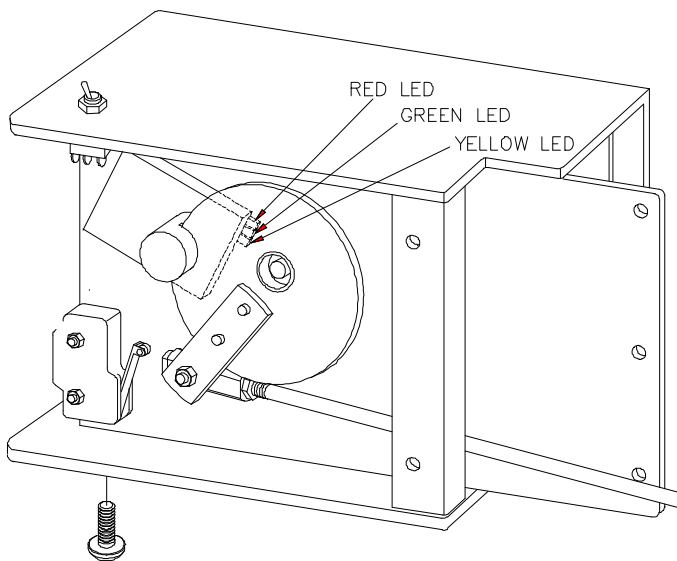

POWER SUPPLY LED

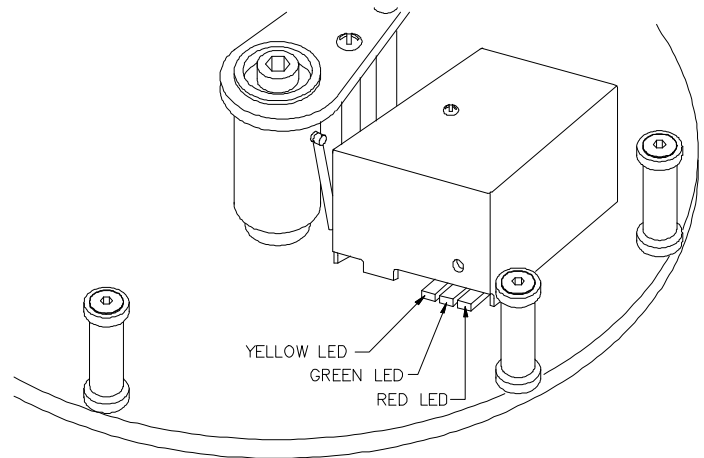

CONTROL PLATE LED

Power Supply DMC Removal. (refer to part manual diagrams)

- a) Turn power OFF and remove the power supply cover.
- b) Remove two screws and the power supply tray.
- c) Remove the hex nut holding the linkage rod to the sensor disk.
- d) While holding the sensor disk, remove the hub allen screw.
- e) Carefully slide the sensor disk away from the DMC card, unplug and remove.
- f) Install in the reverse order.

Control Plate DMC Removal. (refer to parts manual diagrams)

- a) Remove the 1/4" nut and the spring keeper (bottom side).
- b) While holding the sensor arm, remove the hub allen screw.
- c) Carefully slide the sensor arm away from the DMC lens mount.
- d) Remove the last two 1/4" nuts holding the DMC card, unplug and remove.
- e) Install in the reverse order.

Feed Caster Diode Checking

This process uses a digital mutimeter to check the status of a DMC Feed Castor Diode.

1. Turn all of the Make-Up switches to off (down).
2. Put the Black meter lead into the common receptacle and the red meter lead into the Voltage receptacle of the meter.
3. Turn the meter to the audible diode checker.
4. Un plug the motor from an arm and put the black lead into receptacle 2 of the arm and the red lead into receptacle 3 of the arm.
5. Check readings against the following chart.
6. Repeat steps 4-5 for all of the arms.

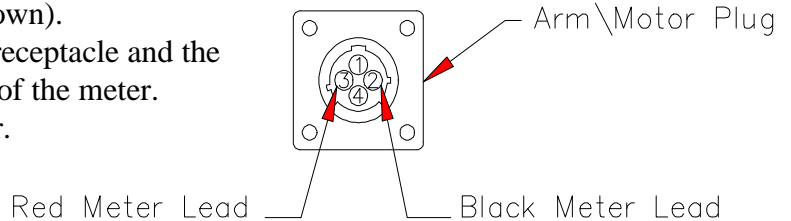

Beep Reading of .090-.200	No Beep Reading of OL (infinity)	Continuous Beeb Reading of near 0
Diode is in the circuit and working correctly	Diode is missing, reversed, open, or Make-Up switch is on	Diode is shorted

If you don't have a diode checker then the resistance of the diode should be approximately 480 ohms.

This diode is a #1N5822 Shottky Diode with a .1 to .2 forward voltage drop. It can be ordered as Part number 3359 (Feed Caster Diode with clips).

TROUBLE SHOOTING

The modular power supply is equipped with PTC's (electronic circuit breakers) on each of the three power supply modules. The three modules are connected in parallel so that all three power supply modules have to fail before you lose arm lighting and control plate DMC LED's. The platter will operate normal (90 feet/min.) with two of the three modules operating. When running platter to platter at the maximum speed (150 feet/min. @ center ring dia.) all three power supply modules are required. When operating in a platter to platter mode and one of the power supplies fails, the PTC's in the other two supplies will trip in two to five minutes.

- 1) If the arm light fails to turn on and the control plate DMC LED's are lit:
 - a) The light bulb or socket is bad.
- 2) If the arm light is lit and the control plate DMC LED's are out:
 - a) The control plate plug in hub or DMC is faulty.
- 3) If the arm lamps, and the control plate DMC LED's fail to turn on:
 - a) Check that the POWER SUPPLY switch is ON
 - b) If a Wrap Detector is installed insure it is not tripped.
 - c) Check the power supply fuse (all three power supply modules are failed)
 - d) Check the power supply PTC's (see below).
- 4) To reset the power supply module PTC's (electronic circuit breaker).
 - a) Turn OFF the power supply switch and wait for 3 to 5 minutes.
 - b) Turn ON the power supply switch.
- 5) To verify that all three power supply modules are operating.
 - a) Turn the power supply switch OFF.
 - b) Lower the take-up carriage to the bottom (fail safe position).
 - c) Remove all three 1 ½ amp power supply fuses.
 - d) Turn the power supply switch ON.
 - e) Install one of the three fuses into arm #1 fuse holder, the arm lights and control plate DMC LED's will light. If the lights do not light the power supply modular is faulty or it's PTC is not reset.
 - f) Repeat step (e) for arm #2, and #3 fuse holder (one at a time). Each power supply should light the arm lights and control plate DMC LED's.
 - g) If you find a faulty module you can operate normal (90 feet/min.) without problems. The system is designed to operate on two modules.
- 6) Checking power supply voltages.
 - a) With the power supplies operating properly you should see 35 +/- 5vdc between pin #3 red wire (+35vdc), and pin #2 black wire (ground) at the control plate DMC plug.
- 7) If the PAYOUT platter runs continuously
CAUTION: DO NOT CHANGE CONTROL PLATES
 - a) Check the feed castor diodes as outlined in the Feed Castor Diode Checking section on page 6.
 - b) If a diode is bad replace the diode and replace the damaged control plate. If another control plate is used with a bad diode damage will occur to the control plate.
 - c) If diode is good see control plate DMC calibration.
 - d) If after recalibration the platter still runs continuously then try a different control plate.
- 8) If the PAYOUT platter does not operate.
 - a) Make sure the make-up switch is set to "0" (off).
 - b) Make sure the drive motor is engaged.
 - c) Make sure the control plate arm moves freely and the control plate is threaded properly.
 - d) Make sure the feed castor is in it's lower position, (see FEED CASTOR SWITCH ADJUSTMENT)
 - e) See control plate DMC LED error indication.
 - f) See control plate DMC calibration.
- 9) If the REWIND platter runs continuously
CAUTION: DO NOT CHANGE THE Take-Up DMC card
 - a) Check the feed castor diodes as outlined in the Feed Castor Diode Checking section on page 6.
 - b) If a diode is bad replace the diode.
 - c) If diode is good see Take-Up DMC calibration.
 - d) If after recalibration the platter still runs continuously then replace Take-Up DMC card.

- 10) If the REWIND platter does not operate.
 - a) Make sure the make-up switch is set to "0" (off).
 - b) Make sure the drive motor is engaged.
 - c) Check that the FAILSAFE SWITCH is not engaged.
 - d) The program must be started with the take-up carriage at the top of it's travel.
 - e) Make sure the feed castor is in it's upper position. (see FEED CASTOR SWITCH ADJUSTMENT)
 - f) See take-up DMC LED error indication.
 - g) See take-up DMC calibration.
- 11) If the system fails to shut down at the end of the program or after film breakage:
 - a) See FAILSAFE SWITCH ADJUSTMENTS.
 - b) If adjustment does not correct the problem, replace the switch.
- 12) If a drive motor operates in REWIND, but fails to operate in PAYOUT, see DMC error indication. Swap the control plate with one from another platter, known to be good. If the problem follows the control plate, it requires servicing.
- 13) Drive motors and feed castors can also be tested by swapping them with one from another platter, known to be good. If the problem follows the swapped component, it requires servicing.

MAINTENANCE

Maintenance ease has been designed into this platter system with all controls and power supplies readily accessible. LED's on the DMC circuit boards provide system status.

- 1) Annually check the feed caster diodes as outlined in the Feed Caster Diode Checking section on page 6.
- 2) Keep the platters, control plates, and pulleys clean. Prevention of oil and lint build-up is important. Alcohol is a suitable cleaning agent for this purpose.
- 3) Check for levelness of the Platter System periodically. Use the leveling bolts on the bottom of the legs to make adjustment.
- 4) Screws, bolts, and nuts should be periodically checked for tightness.

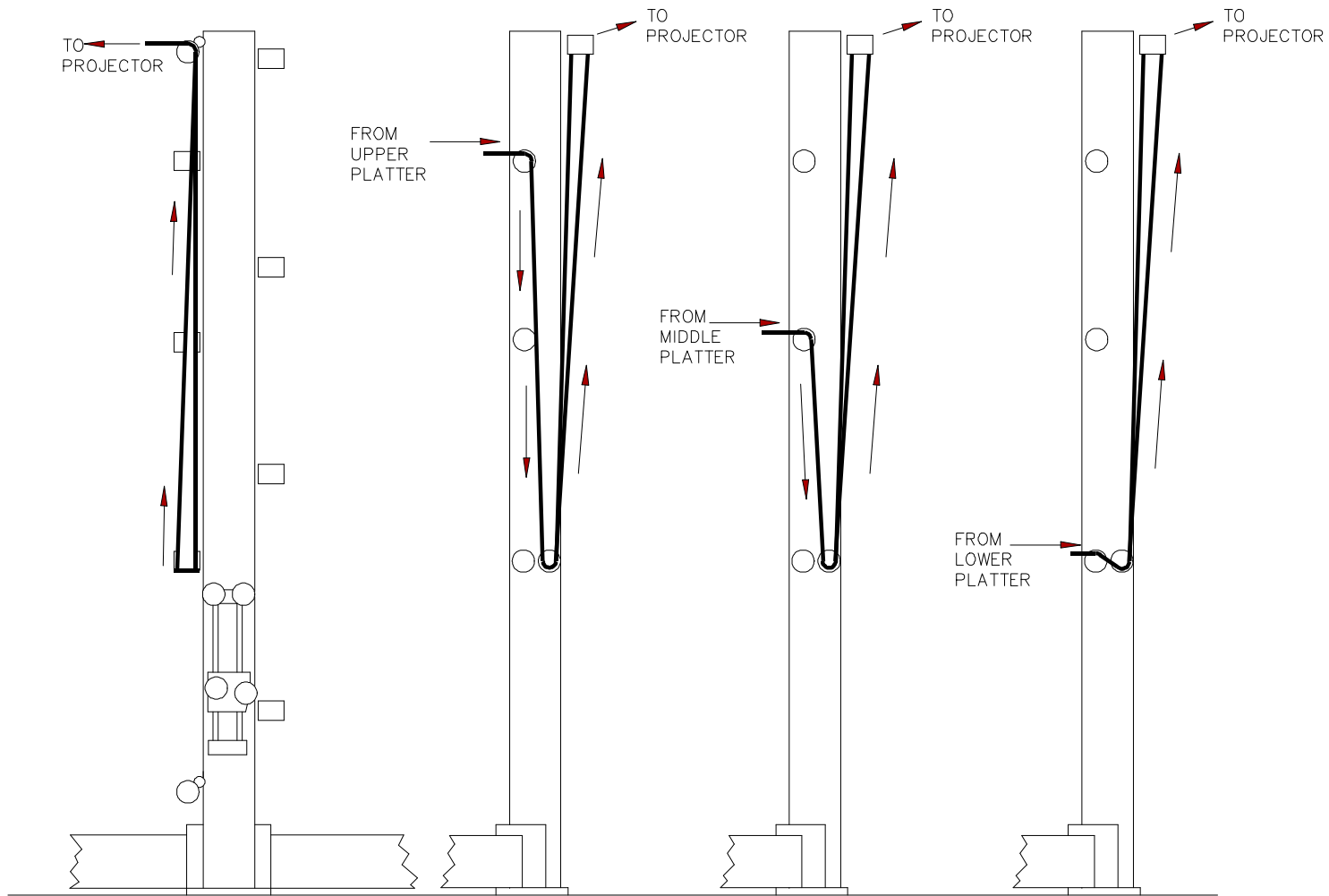

REAR VIEW
SHOWING FEED-OUT
TO PROJECTOR

THREE PLATTER FEED-OUT, UPPER,MIDDLE, AND LOWER PLATTERS

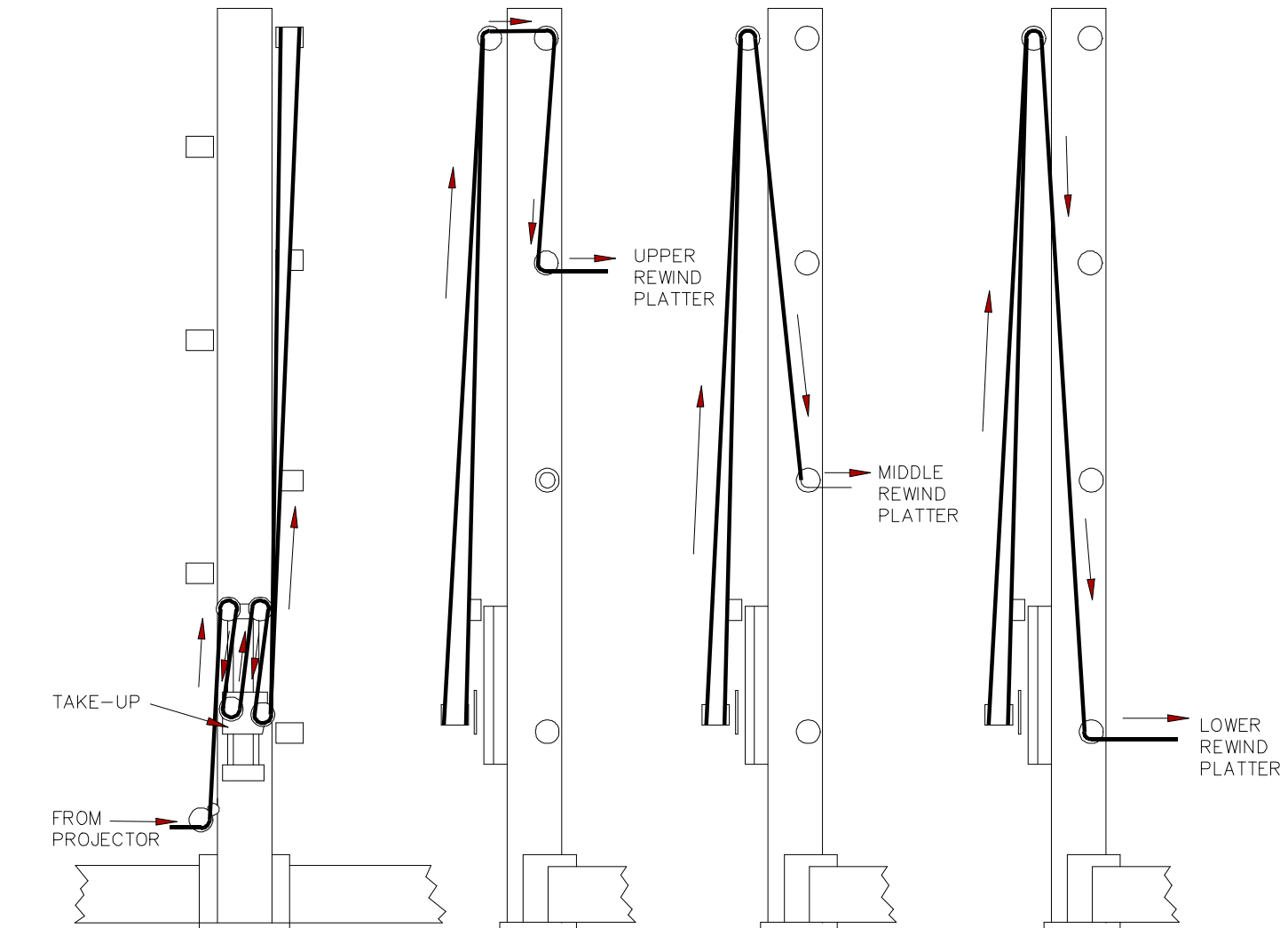

REAR VIEW
 SHOWING RETURN
 FROM PROJECTOR

THREE PLATTER REWIND, UPPER, MIDDLE, AND LOWER PLATTERS

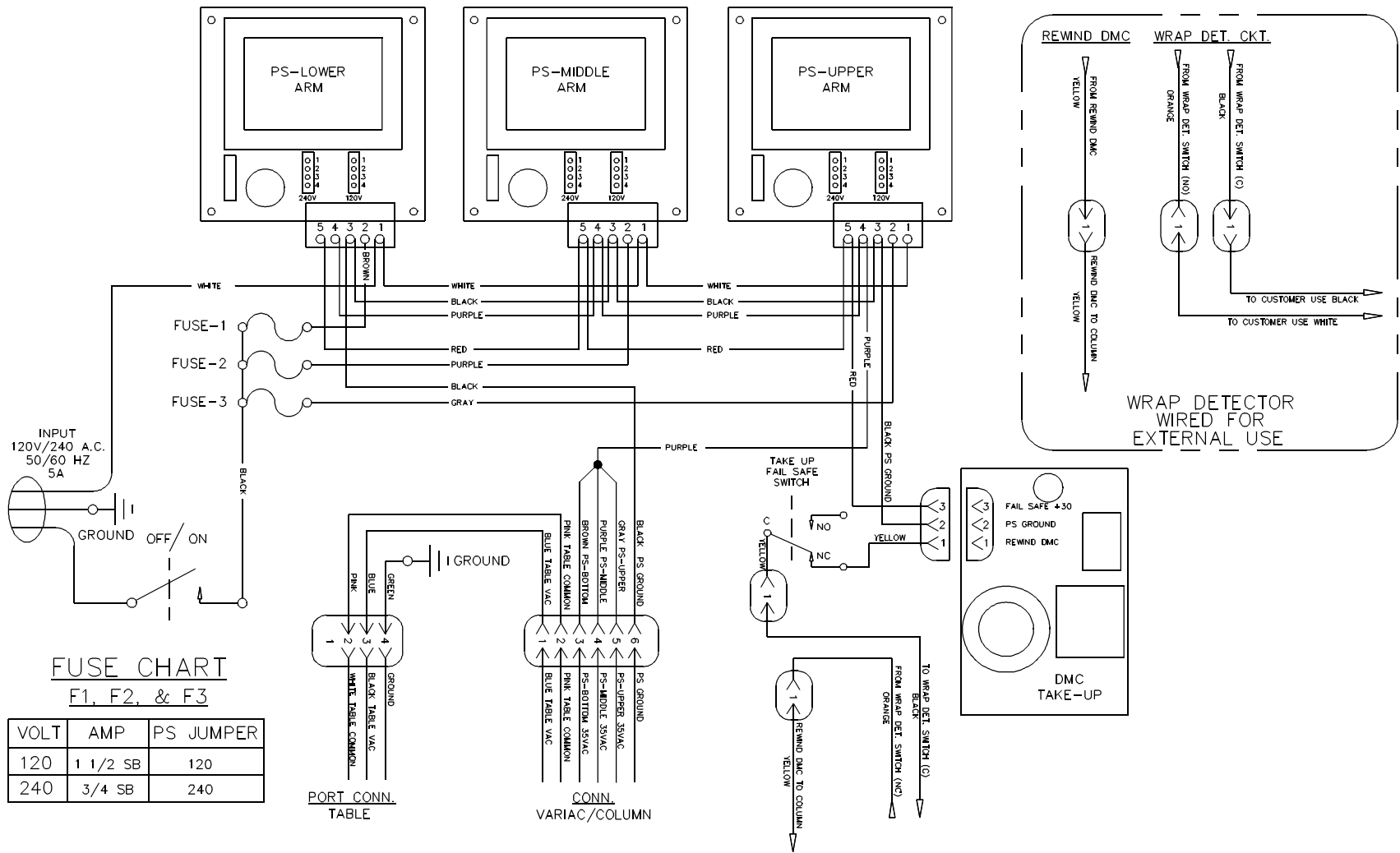

DMC WIRE SCHEMATIC, PAGE 1 OF 3

CONTROL PLATE DMC PLUG CONNECTOR

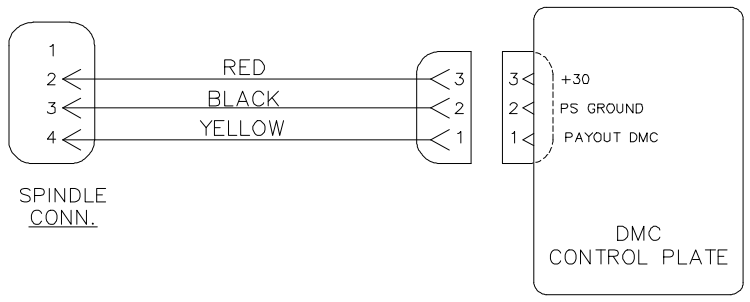

ARM LAMP

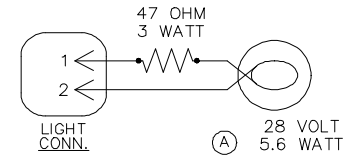

DMC POWER SUPPLY CONNECTIONS FOR EXTERNAL USE WRAP DETECTOR

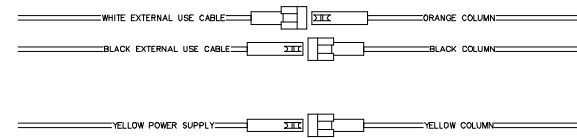

DRIVE MOTOR DMC

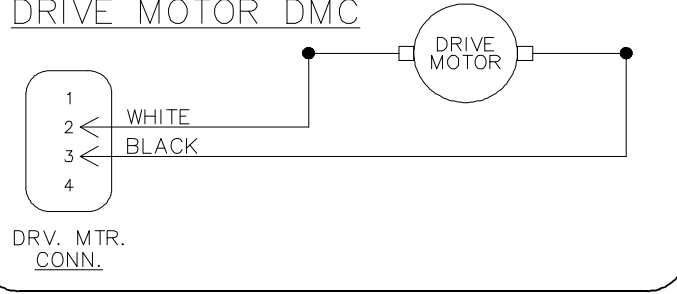

DMC POWER SUPPLY CONNECTIONS FOR INTERNAL USE WRAP DETECTOR

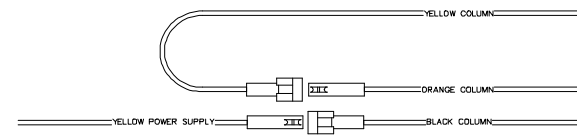

IMPORTANT SAFETY INSTRUCTIONS

1. Read and understand all instructions before using.
2. Do not operate appliance with a damaged cord or if the appliance has been dropped or damaged-until it has been examined by a qualified serviceman.
3. Position the cord so that it will not be tripped over, pulled or contact hot surfaces.
4. If an extension cord is necessary, a cord with a current rating at least equal to that of the appliance should be used. Cords rated for less amperage than the appliance may overheat.
5. Always unplug appliance from electrical outlet before cleaning and servicing and when not in use. Never yank cord to pull plug from outlet. Grasp plug and pull to disconnect.
6. To reduce the risk of electric shock, do not use this product near water or other liquids.
7. To reduce the risk of electric shock, do not disassemble this appliance. Refer all work to a qualified serviceman when service or repair work is required. Incorrect reassembly can cause electric shock when the appliance is used subsequently.
8. The use of an accessory attachment not recommended by the manufacturer may cause a risk of fire, electric shock or injury to persons.
9. Connect this appliance to a grounded outlet.
10. Disconnect this unit from It's source of supply before replacing the lamps.

SAVE THESE INSTRUCTIONS