

AP 5-Deck Operation Manual

SUPPLEMENT

PRODUCT INFORMATION BULLETIN #3764

Record Platter System Identification Numbers Here:

Model # _____ Serial # _____

The information presented in this manual applies to all AP 5-Deck Platter Systems. It is intended to be used as a supplement to the A.P. Operation Manual, #3001.

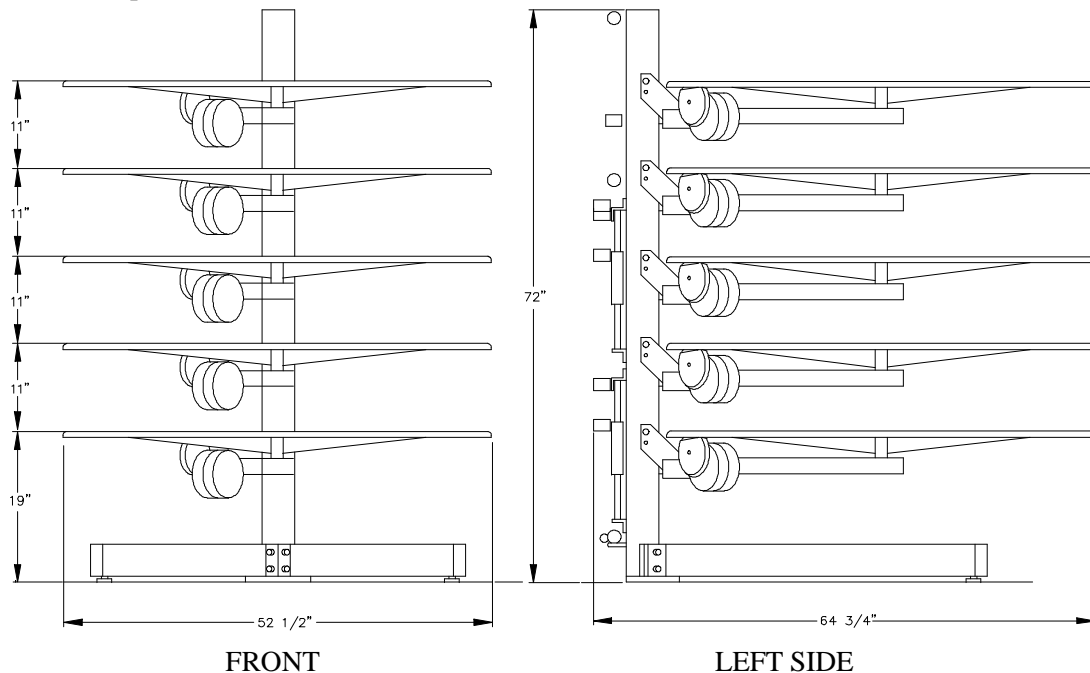

FRONT

LEFT SIDE

AP5 35MM
AUTOMATIC PROGRAMMING
52" DIA. DISKS
WEIGHT: 600 POUNDS

POWER SOURCE

The AP 5-Deck Platter System requires two 110/120 Volt AC, 50-60 Hz, 10 Amp grounded power outlets

GENERAL

The AP 5-Deck Platter System is designed to supply film to two projectors simultaneously. The top two platters operate with one projector and the bottom two platters with the other. The center platter can be operated with either. To use the center platter with the top two platters the toggle switch on the side of the column must be in the upper position. To use it with the bottom two platters the switch must be in the lower position. The center position is OFF, disabling the center platter.

PROGRAM RUN

PROGRAM RUN is explained in the AP Platter System Operation Manual #3001. The threading diagrams for the A.P. 5-Deck System are in this manual (See pages 4 through 7).

PIB 3764 R7/10/98 Page 1

IMPORTANT SAFETY INSTRUCTIONS

1. Read and understand all instructions before using.
2. Close supervision is necessary when any appliance is used by or near children. Do not leave appliance unattended while in use.
3. Do not operate appliance with a damaged cord or if the appliance has been dropped or damaged-until it has been examined by a qualified serviceman.
4. Position the cord so that it will not be tripped over, pulled or contact hot surfaces.
5. If an extension cord is necessary, a cord with a current rating at least equal to that of the appliance should be used. Cords rated for less amperage than the appliance may overheat.
6. Always unplug appliance from electrical outlet before cleaning and servicing and when not in use. Never yank cord to pull plug from outlet. Grasp plug and pull to disconnect.
7. To reduce the risk of electric shock, do not use this product near water or other liquids.
8. To reduce the risk of electric shock, do not disassemble this appliance. Refer all work to a qualified serviceman when service or repair work is required. Incorrect reassembly can cause electric shock when the appliance is used subsequently.
9. The use of an accessory attachment not recommended by the manufacturer may cause a risk of fire, electric shock or injury to persons.
10. Connect this appliance to a grounded outlet.
11. Disconnect this unit from It's source of supply before replacing the lamps.

SAVE THESE INSTRUCTIONS

PROGRAM RUN

PROGRAM RUN is explained in the AP Platter System Operation Manual #3001. The threading diagrams for the AP 5-Deck System are in this manual (See pages 6 through 9).

PLATTER TIMING

The purpose of PLATTER TIMING is to insure that all platters run at approximately the same speed for a given VARIAC setting. Film may be left on the platters during timing but all film must be played out, not routed through pulleys. The AP 5-Deck Platter system is timed in two steps; first, the center three platters are timed and then the top two platters are timed to work with the center platter.

1) Place a suction cup bracket or piece of dark tape on the edge of each platter to allow you to count revolutions easily.

2) Set one motor in the disengaged position and adjust the motor at the mount until it is $\frac{1}{2}$ " from the bottom of the platter as shown here. Adjust the motor by loosening the two hex screws and sliding the motor up or down. Retighten both hex screws before the next step. Make sure the motor bracket is parallel with the arm. Repeat this step with the other four motors.

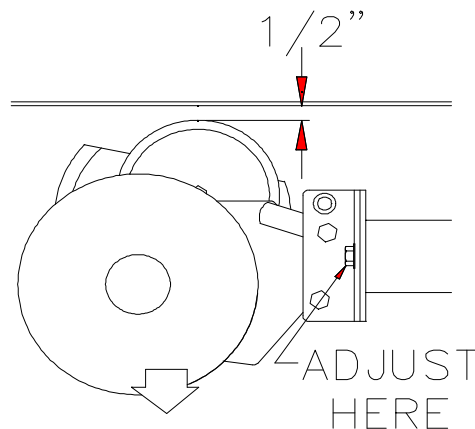

NOTE: The inside hex screw on the bottom motor may be difficult to reach because of the variac location. Temporarily disconnect the motor from the arm to allow more working room.

3) Plug the make-up table into the table port on the variac. Turn the speed control knob on the make-up table all the way counterclockwise (off). Turn the table power switch on. Place the switch on the side of the column in the down position.

4) Engage the bottom three three drive motors. Set the MAKE-UP SWITCH on the center platter to "1" (on). Use the speed control knob on the make-up table to increase the speed of the platter until it is turning approximately 1 revolution in 3 seconds, using the tape or suction cup to count each revolution. This is approximately 20 RPM.

NOTE: It is important that you allow the platter speeds to stabilize before each check. Allow several revolutions before comparing speeds.

Platter Timing (continued)

- 5) Set the MAKE-UP SWITCHES on the lower two platters to "1" (on). After the platters have come up to speed and stabilized, determine which of the three platters is fastest by observing the relative positions of the suction cups or tape markers. Switch the MAKE -UP SWITCH of one of the three lower motors to "O" (off). Compare the fastest of the three platters to the remaining rotating platter. When the markers on both platters come into alignment, count 5 revolutions of the fastest plate. The slower platter should not be more than 1/4 revolution behind the faster platter after 5 revolutions. If it is, increase the speed of the slower motor (see MOTOR SPEED ADJUSTMENT).
- 6) If you are unable to increase the speed of the slower motors sufficiently to match the fastest motor, decrease the speed of the fastest motor as directed in the motor speed adjustment procedure and repeat step 5.
- 7) After the lower three platters are timed, move the switch on the side of the column to the up position. Repeat the timing process on the upper two platters, timing them to match the speed of the center platter. Do not change any adjustments on the center platter unless the speed of the upper two motors can not be increased enough to match the center motor. If this situation occurs, repeat the timing on the lower three platters at a slower speed, switch to the upper platters and time to match the slower speed.
- 8) Disconnect the make-up table from the variac.

MOTOR SPEED ADJUSTMENT

- 1) Disengage the drive motor and set the make-up table power switch to OFF. Loosen the two hex screws that hold the drive motor to the platter arm.
- 2) To increase platter speed, lower the drive motor. To decrease platter speed, raise the drive motor. Adjustments should be made 1/16" at a time. Retighten the hex screws.
- 3) Do not over adjust the drive motor. When the drive motor is disengaged, the drive wheel must not be in contact with the platter. When the drive motor is engaged it must be in full contact with the platter and not slip. Check for slippage by holding the motor hub with the power off and the drive motor engaged. You should feel resistance as you manually rotate the platter while holding the hub. Over engagement causes the platter to creep up on the spindle.

5-DECK VARIAC ADJUSTMENTS

CAUTION: TO AVOID ELECTRICAL SHOCK HAZARD turn the variac power switch to OFF and unplug the variac power cord before making any variac adjustments.

Slight differences in the power settings of the two variacs may cause the center platter to run at different speeds in the upper and lower switch positions. To correct this, use the following procedure to determine which variac to adjust.

- 1) Place a suction cup bracket or piece of masking tape on the edge of the center platter.
- 2) Engage the drive motor and set the DRIVE MOTOR SELECTOR SWITCH to REWIND. Set the VARIAC power switch to ON.
- 3) Raise both take-up plates and push the spring loaded pins into the lower hole in the back of the column. The take-up plates should remain in the raised position.
- 4) Place the switch on the side of the column in the upper position. Using the suction cup or tape marker, count the number of revolutions in a thirty second period. Now place the switch in the lower position and time it again.
- 5) If the center platter is faster in the upper switch position, the arm mounted variac needs to be adjusted. If it is faster than the lower position, the leg mounted variac needs to be adjusted.

To make the variac adjustment, use the ELECTRICAL ZERO ADJUSTMENT procedure in the A.P. Platter System Operation Manual #3001, but rotate the radius arm keeper one more degree clockwise than the previous setting.

Now recheck the timing on the center platter. Repeat the procedure if necessary, however, it is important not to over adjust. The drive motor should stop completely when the take-up is at the top of its travel.

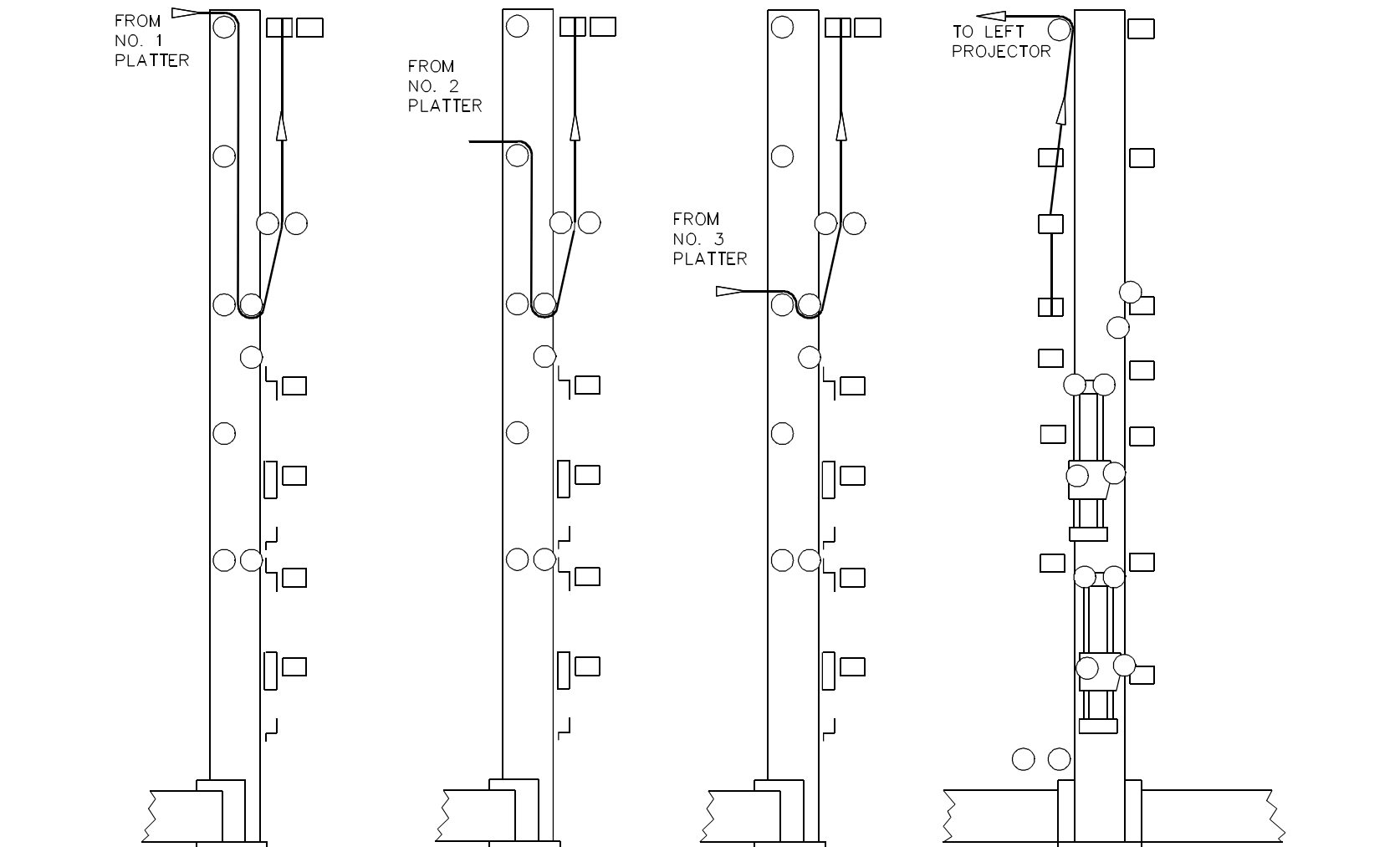

REAR VIEW SHOWING
 PLATTERS 1,2 & 3
 FEEDING-OUT TO LEFT PROJECTOR

FIVE PLATTER FEED-OUT, PLATTERS 1, 2 & 3

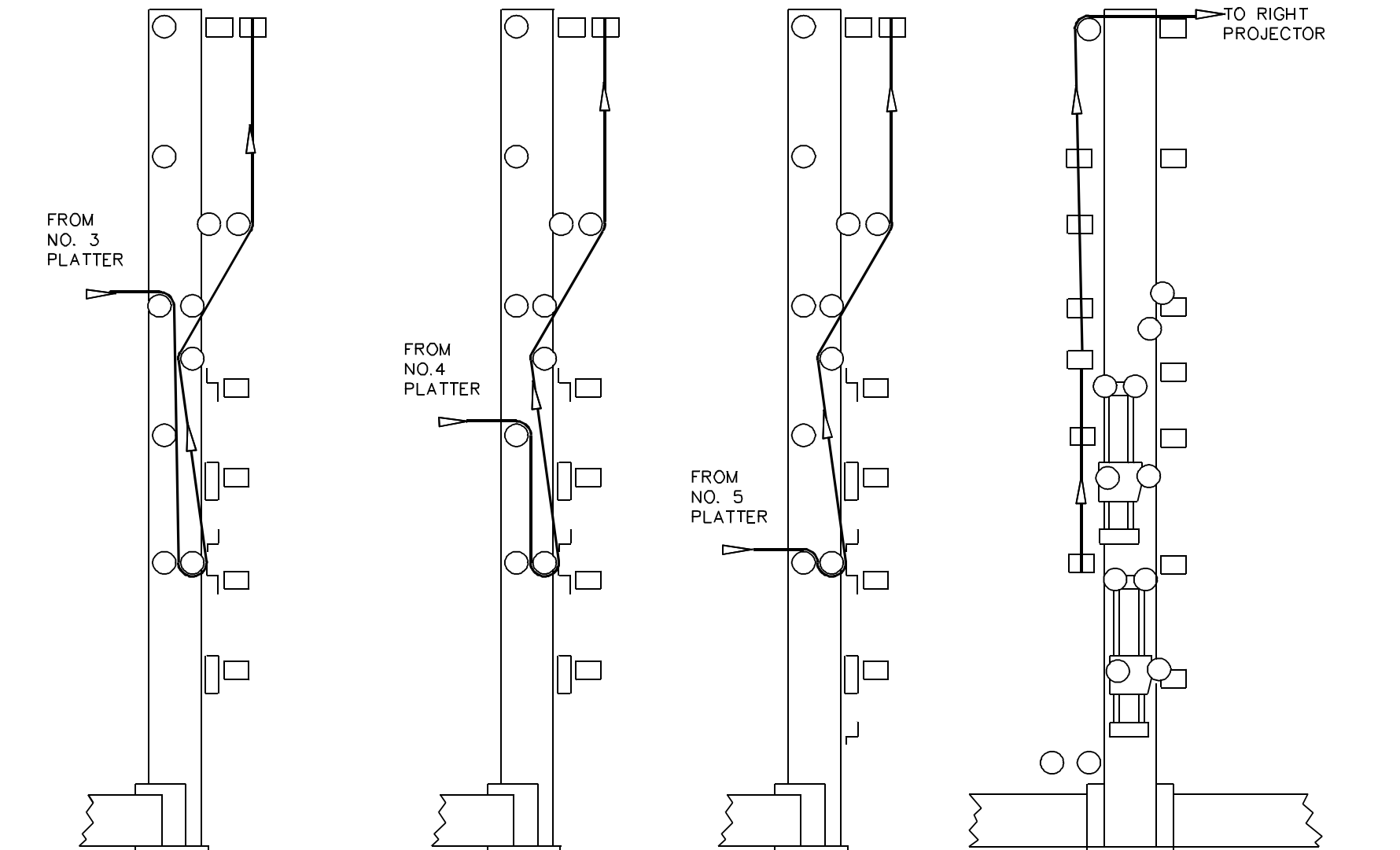

REAR VIEW SHOWING
 PLATTERS 3,4 & 5
 FEEDING-OUT TO RIGHT PROJECTOR

FIVE PLATTER FEED-OUT, PLATTERS 3, 4 & 5

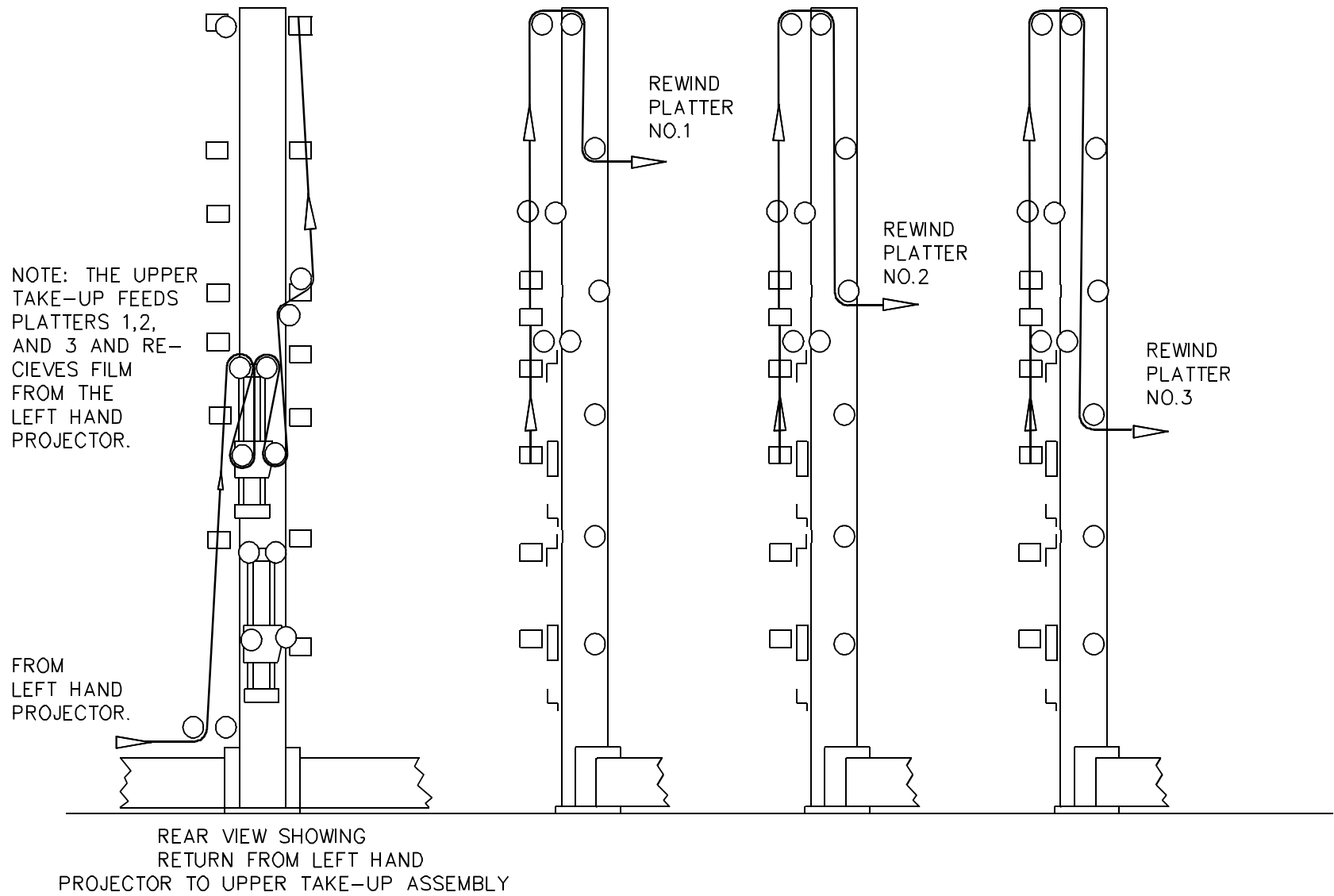

FIVE PLATTER REWIND FROM LEFT PROJECTOR TO PLATTERS 1, 2 & 3

NOTE: THE LOWER TAKE-UP FEEDS PLATTERS 3,4 AND 5 AND RECEIVES FILM FROM THE RIGHT HAND PROJECTOR.

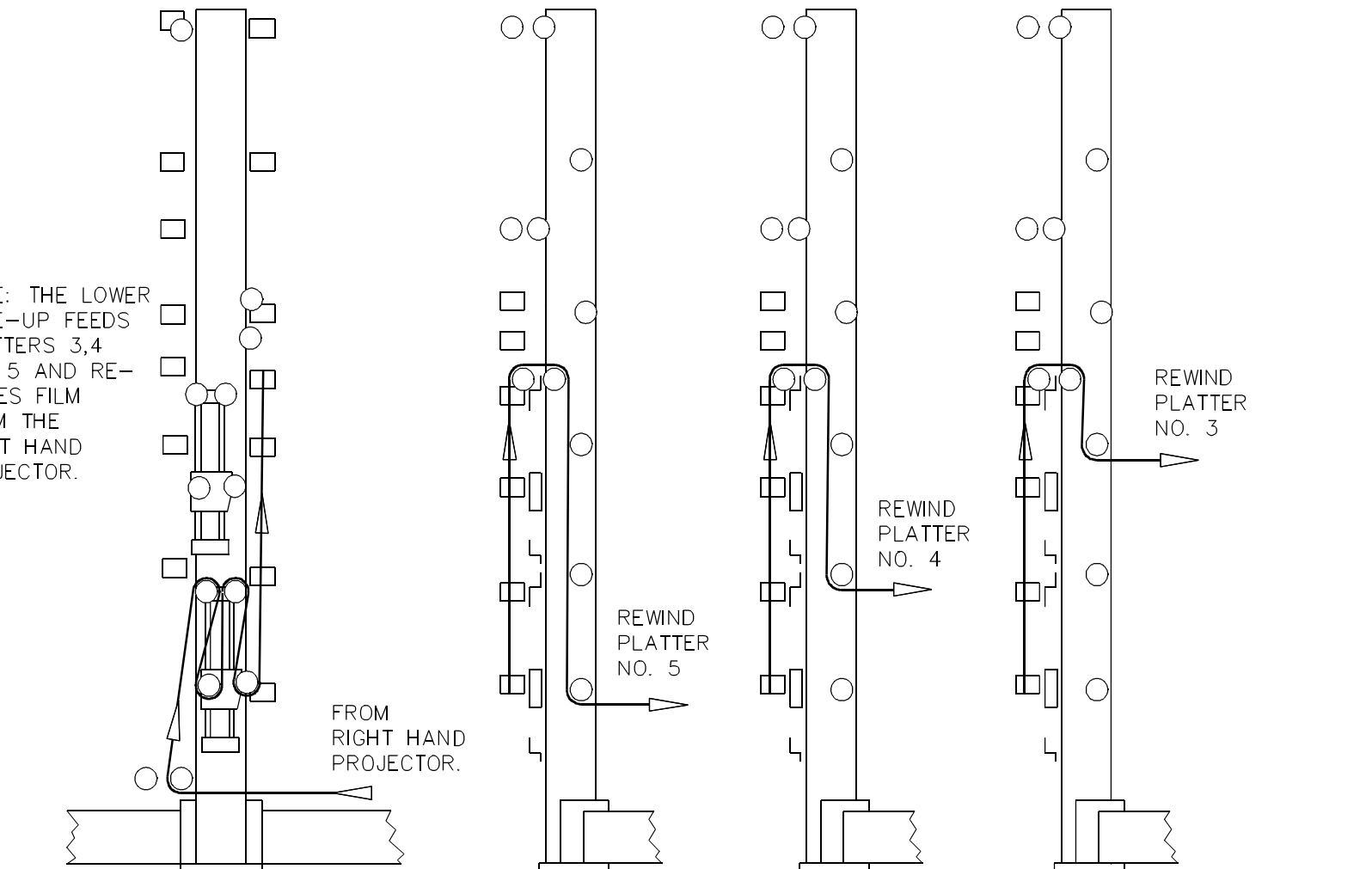

FIVE PLATTER REWIND FROM RIGHT PROJECTOR TO PLATTERS 3, 4 & 5

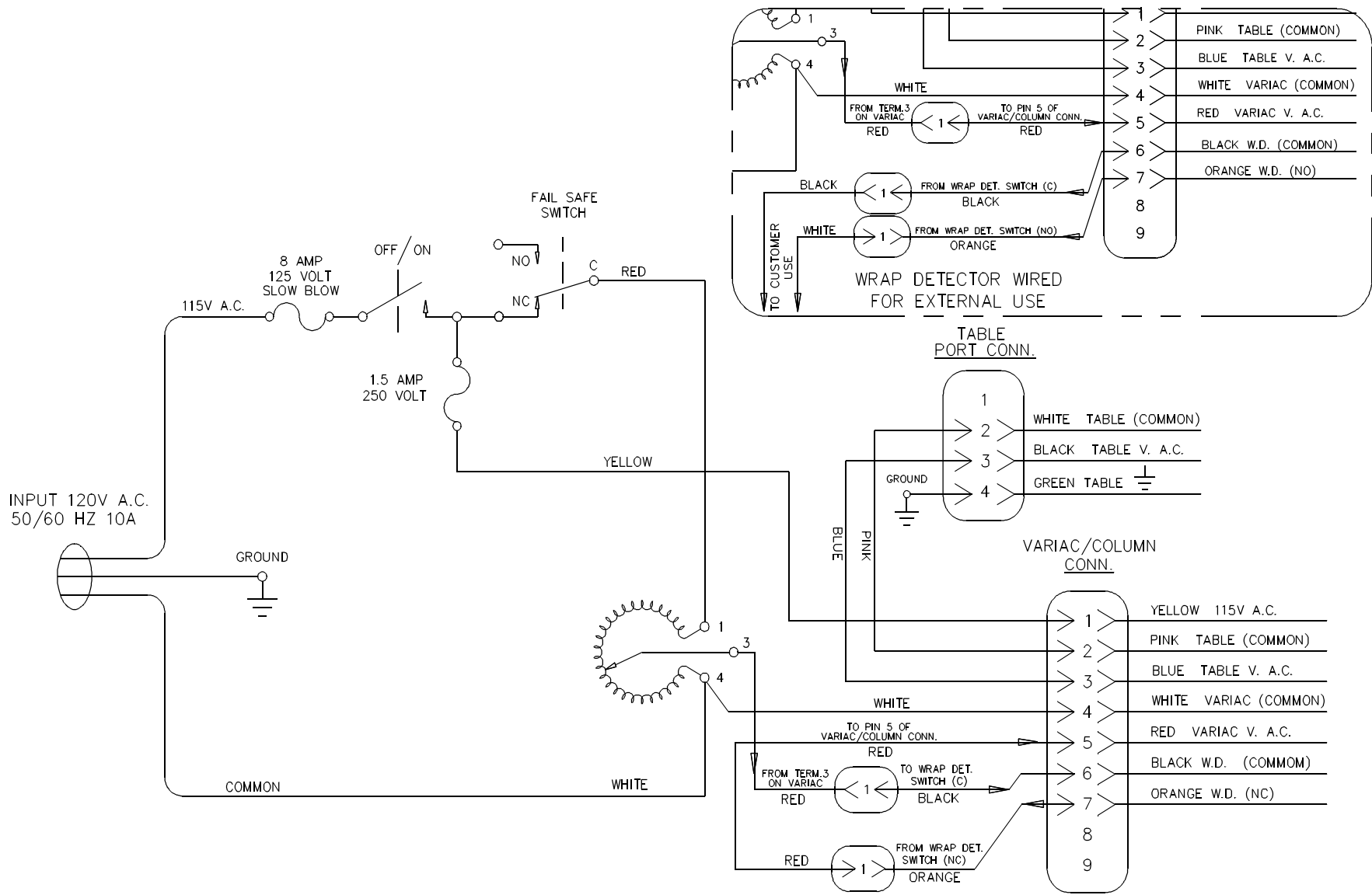

A.P. 5 ARM MOUNT VARIAC WIRE SCHEMATIC

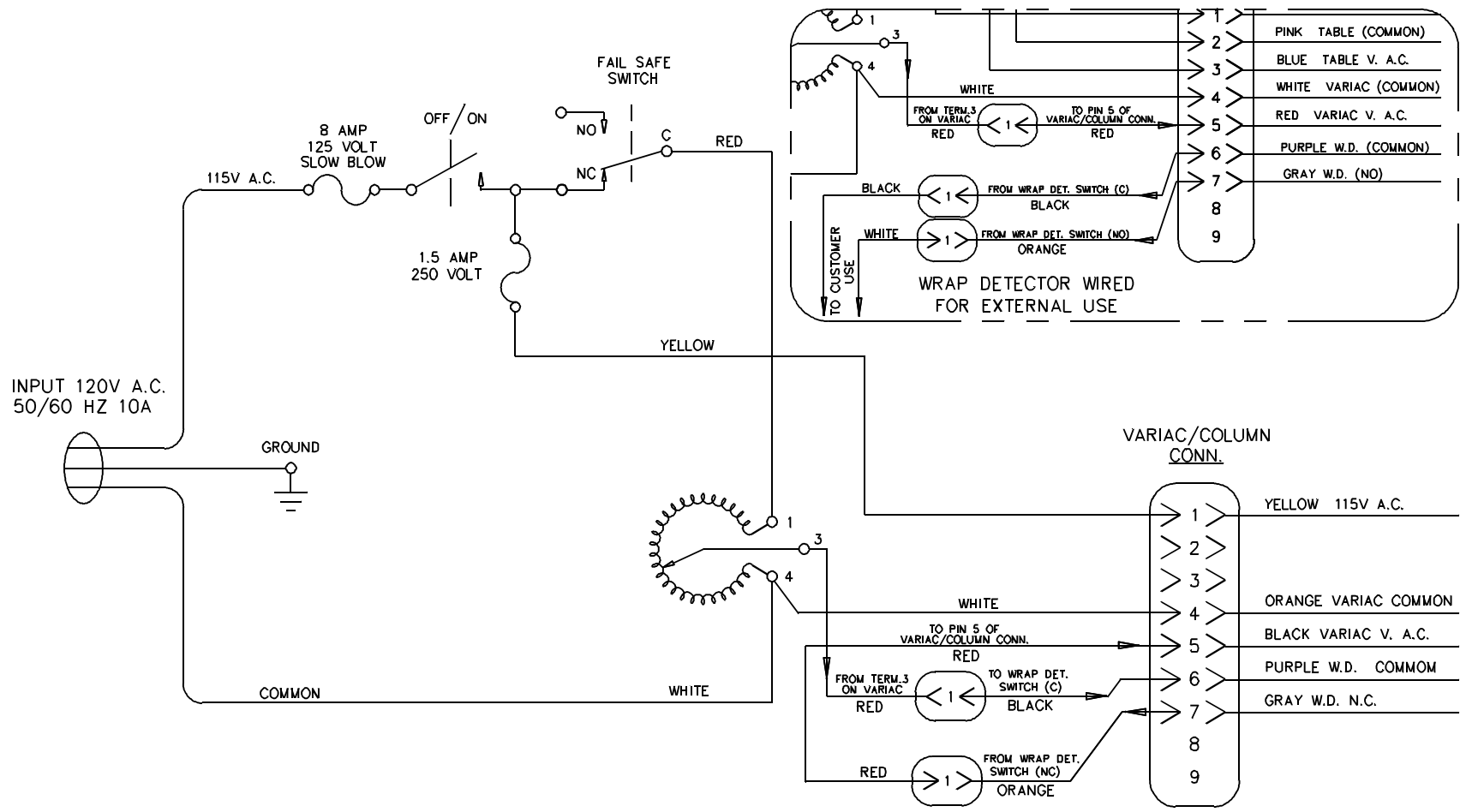

A.P. 5 COLUMN MOUNT VARIAC WIRE SCHEMATIC

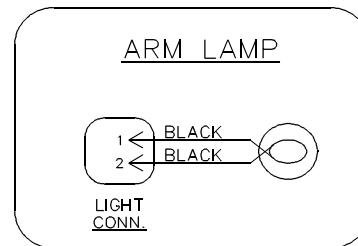
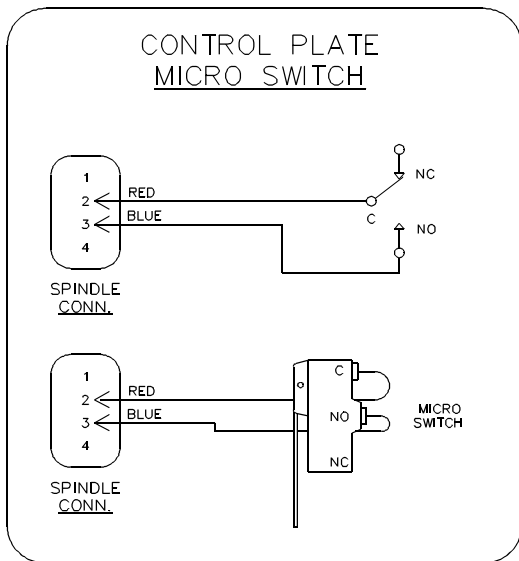
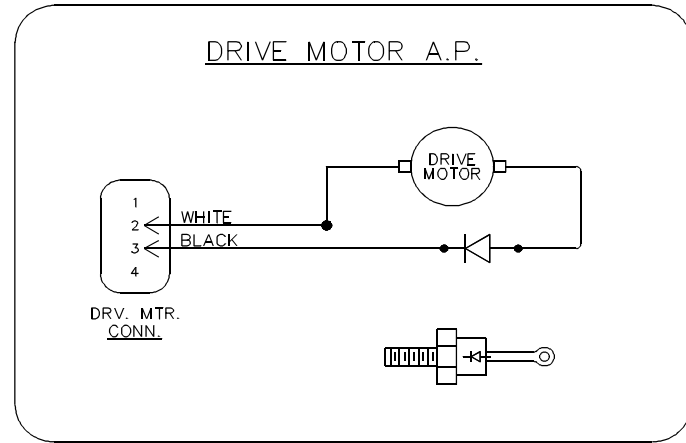
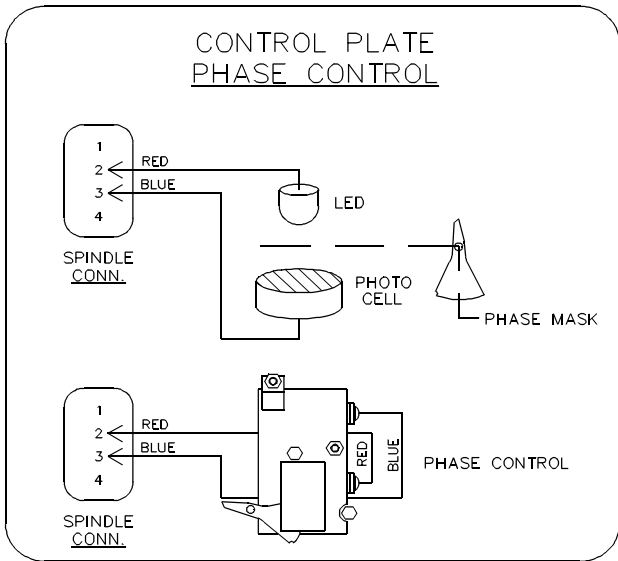

A.P. 5 WIRE SCHEMATICS