

INSTRUCTION MANUAL

XENON POWER SUPPLY

4 - 7 kW

TYPE 62-84000



STRONG INTERNATIONAL, Inc.
4350 McKinley St. Omaha, NE 68112
402/453-4444 FAX 402/453-7238

PREFACE

The Strong International switching power supply Type 62-84000 is designed to operate a xenon bulb in all cinema lighting applications for Strong lamphouses. This unit will operate all xenon bulbs rated from 4000 to 7000 watts throughout their full operating ranges (29 - 49 V.DC, 90 - 160 A.DC). The power requirement for this unit is 208/230 (200 - 240) volts AC, 30 ampere, three phase, 50/60 Hz.

Incoming line power is transformed from 208/230 volt alternating current to a low voltage, high current DC output. The incoming AC line is filtered to eliminate noise and is then converted to DC. This DC voltage is switched on and off by a solid state switching circuit, and converted to a 25 kHz. square wave. The square wave is fed into output transformers to provide low voltage and high current. Rectifiers convert the 25 kHz. signal to DC, and the output is filtered to eliminate noise and ripple. Output to the xenon bulb is controlled through use of (2) potentiometers (coarse and fine).

A control transformer reduces the incoming line to 120 V.AC to power the lamphouse igniter and blower(s). A separate three ampere circuit breaker protects the control circuit in the event of a lamphouse component malfunction.

The high speed cooling fan operates on 24 V.DC and acts as a bleeder to drain the capacitors after the bulb is extinguished. A thermal switch protects the field effect transistors and the output diodes. This switch will open and interrupt operation of the power supply if internal temperatures exceed 190° Fahrenheit (88° Celsius). The switch will automatically close and restore operation when the excessive heat dissipates.

Loss of one or more phase of the incoming AC power, or a sudden decrease in incoming voltage (brown-out), will also interrupt power supply operation. These conditions are hazardous to the switching circuit, and the power supply will remain out of service until the AC supply line is corrected.

The mother board is protected by a 40 ampere cartridge fuse located adjacent to the AC input terminal block. This fuse is not commonly available, and should be serviced by a factory authorized technician. Do not change this fuse until the power supply has been OFF for at least (20) minutes to allow the capacitors to discharge completely. Consult your Strong International Dealer if this fuse fails repeatedly.

Refer all servicing of this power supply to an authorized Strong International Dealer. There are **no user serviceable** components in this unit.

Complete and return the postpaid Warranty Registration card received with the unit immediately upon installation.

LAMPHOUSE - POWER SUPPLY INTERCONNECTION DIAGRAM

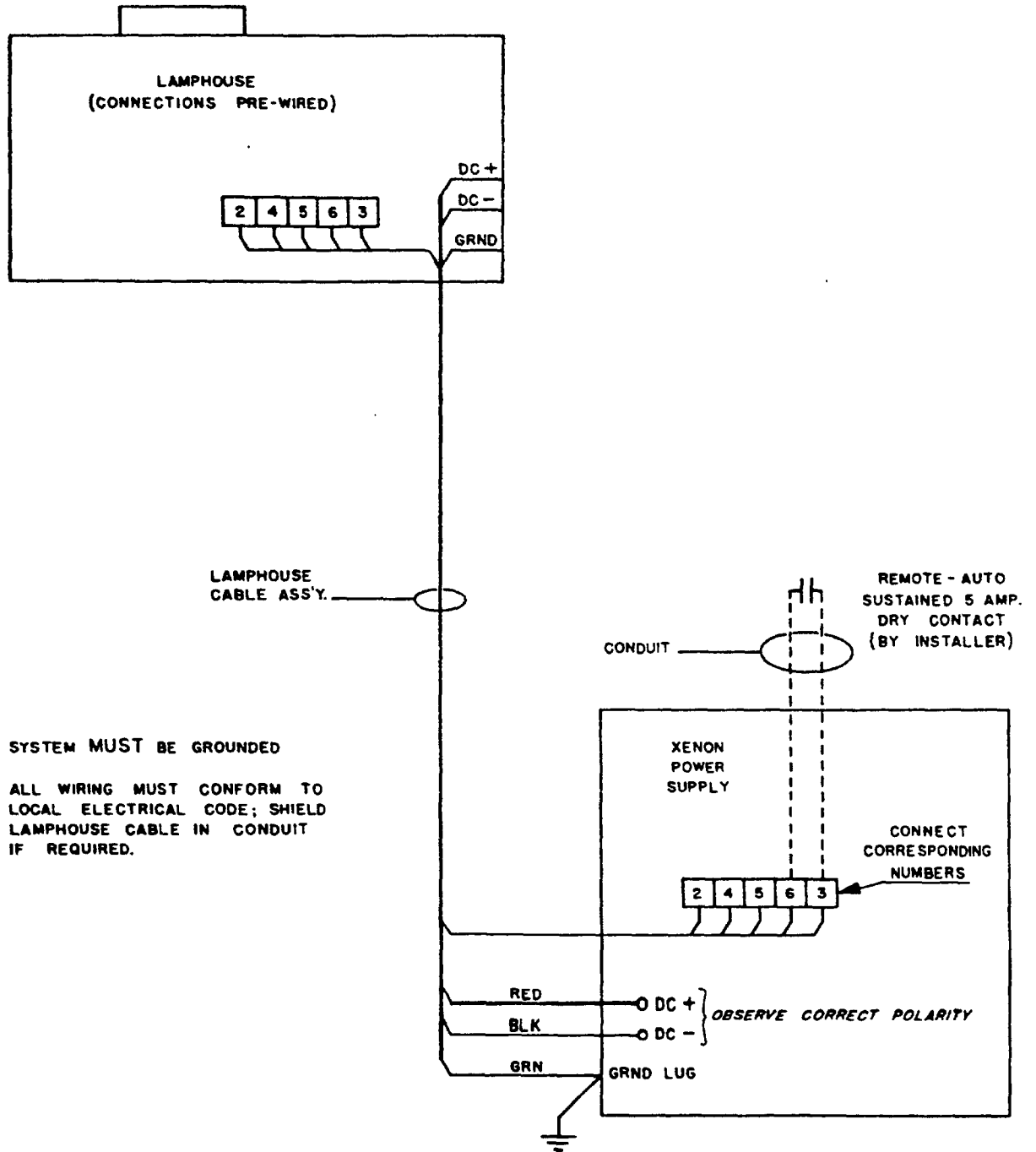

INSTALLATION - OPERATION

CAUTION: High voltages exist inside the power supply enclosure. Remove **only** the (2) small access panels in the power supply cabinet for installation procedures. The input panel is located near the circuit breakers; the output on the opposite corner.

Connect the lamphouse leads to the output side of the power supply prior to connecting to AC power. Lamphouse to power supply connections are illustrated in the lamphouse instruction manual. Make certain the lamphouse is grounded.

Power leads run to the unit must be of the correct size and type to conform to local codes. Shield in conduit as required. The power supply will not energize until the circuit breakers on the side of the cabinet are placed in the ON position.

Connect 208/230 V.AC three phase input to L1, L2, and L3. Single phase neutral is not required for installation of this unit. Attach the ground lug to an adequate ground.

See the warranty information packed with the xenon bulb for correct operating current. **Do not exceed, at any time, the maximum current level specified by the bulb manufacturer.**

Adjust the current output to the bulb through use of the (2) adjustment potentiometers. The FINE and COARSE adjustment potentiometers are located on the access plate used for lamphouse connection. Check the lamphouse ammeter on the first bulb ignition, and adjust the FINE potentiometer to the desired bulb current. Rotate the potentiometer clockwise to increase current, or counterclockwise to reduce current. If the bulb current is too low at the highest setting of the FINE potentiometer, rotate the COARSE potentiometer slightly clockwise. If the bulb current is too high at the lowest setting of the FINE potentiometer, rotate the COARSE potentiometer slightly counterclockwise.

The step-down transformer for the lamphouse control circuit is factory prewired. Terminals 2 & 4 supply 120 V.AC to the lamphouse blower(s). After completing the lamphouse interlock circuit, the 120 V.AC return to the power supply on wires 5 & 6 to close the contactor on closure of the LAMP ON switch. The same (5 & 6) circuit energizes the lamphouse igniter. Terminals 3 & 6 are dry contact switching terminals for remote or automated control. See lamphouse manual Installation Diagram. **Do not** apply voltage to terminals 3 & 6.

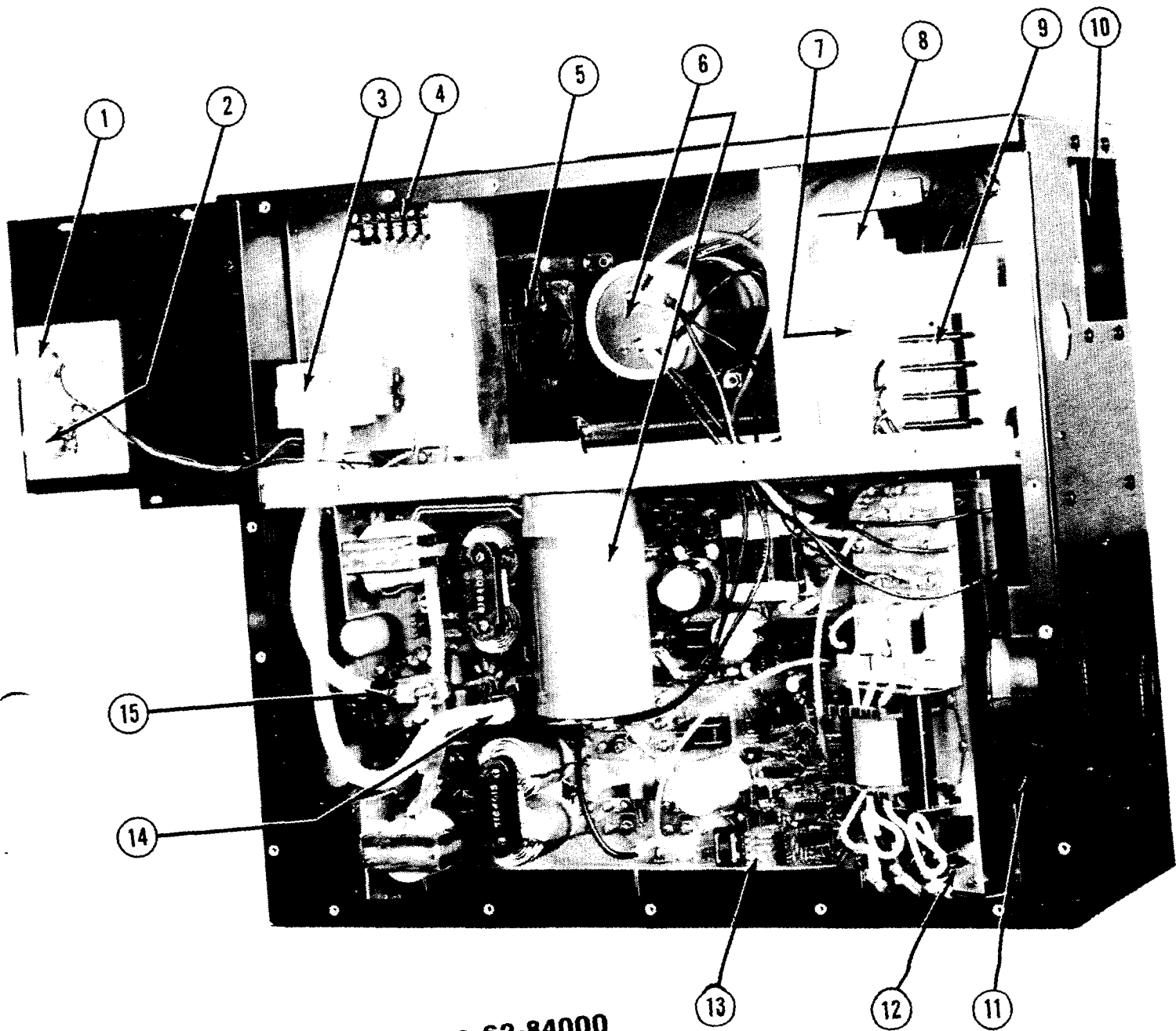

XENON POWER SUPPLY Type 62-84000

SWITCHING TYPE XENON POWER SUPPLY

Model 62-84000

4 - 7 kW

<u>Item</u>	<u>Description</u>
1	Fine Adjustment Potentiometer
2	Coarse Adjustment Potentiometer
3	Lamphouse DC Output Terminal Block
4	Lamphouse Control Circuit Terminal Block
5	Control Circuit Stepdown Transformer
6	Filter Capacitors
7	Input Ground Connector
8	Line Filter
9	Three Phase AC Input Terminal Block
10	Circuit Breaker & Fuse Access Panel
11	Cooling Fan
12	Filter Board
13	Mother Board
14	Positive (+) DC Output Cable
15	Negative (-) DC Output Cable

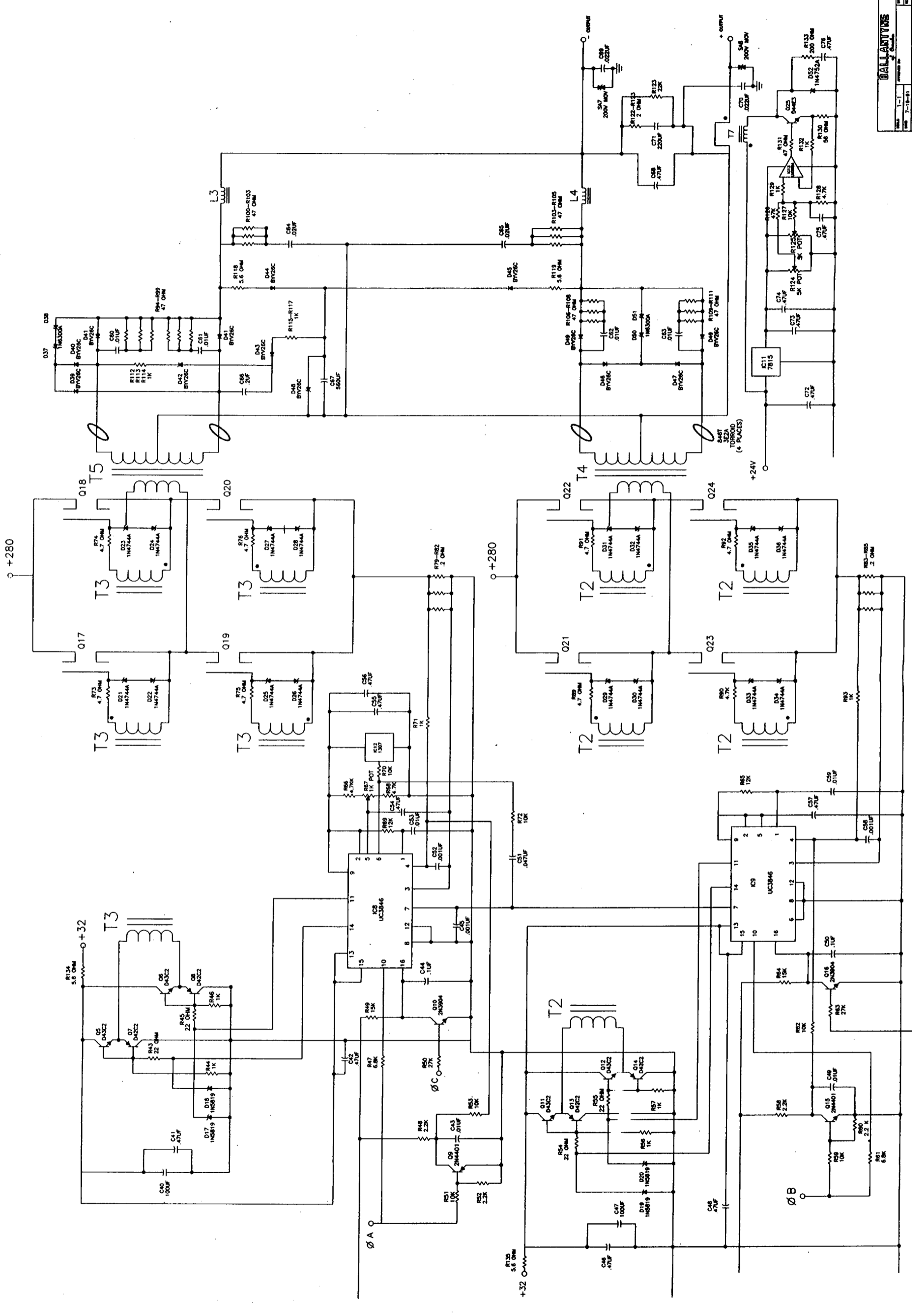

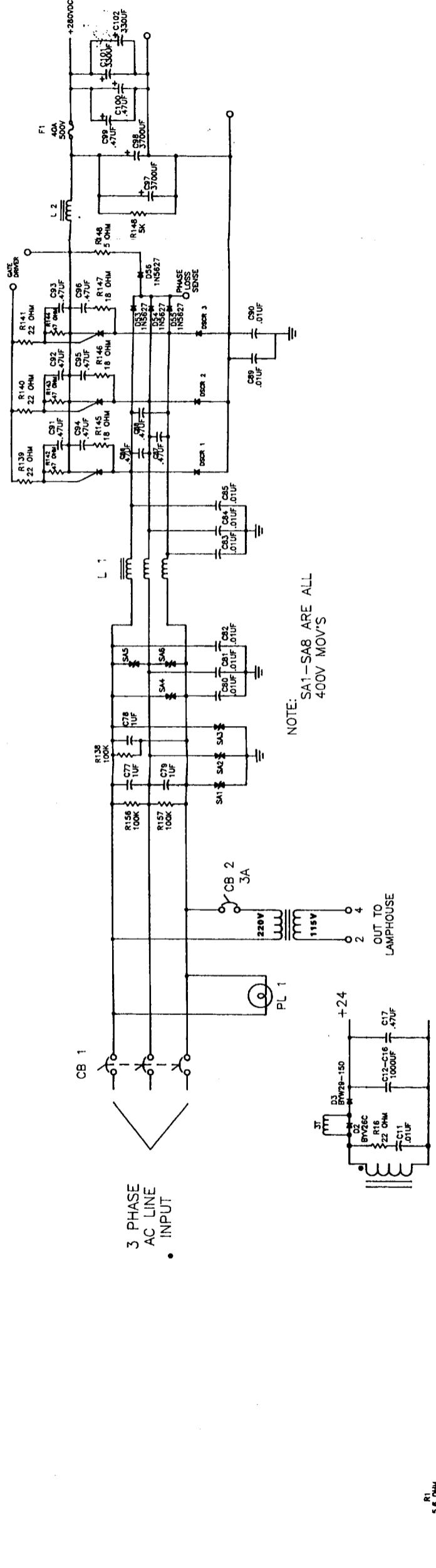

NOTE: SA1-SAB ARE ALL 400V MOV'S

NOTE:
 A=4093B IC2
 B=4093B IC3
 C=4013B IC4
 D=4049B IC5

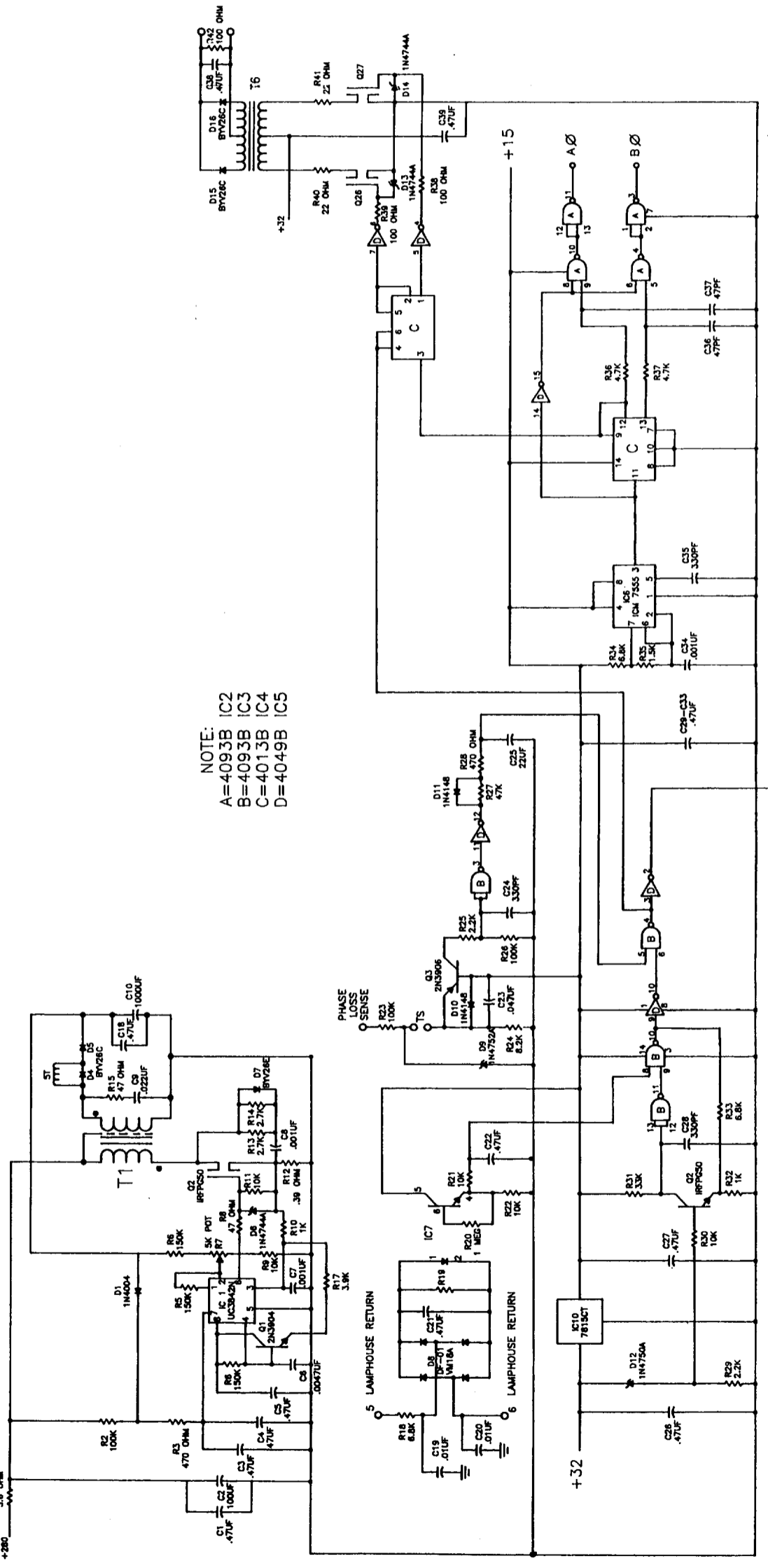

TROUBLESHOOTING

See Lamphouse Manual Before Troubleshooting Power Supply

No Lamphouse Blowers; Power Light ON, Supply ON, Breaker ON

1. Three ampere circuit breaker is tripped. Press to reset.
2. Improper AC connection. Check AC voltage at contactor terminals; should read 190 - 240 V.AC across L1, L2 & L3.
3. Miswired output on terminals 2 & 4. Should read 100 - 120 V.AC; check wire numbers.
4. Defective circuit breaker. Check resistance across circuit breaker CB1 with supply OFF; should measure (0) Ohms. Replace if defective.
5. Defective filter board. Check across each leg of the filter board input and output; should measure 190 - 240 V.AC. Replace as required.
6. Defective step-down transformer (T6). Check input at L1 & L3 on contactor; should measure 190 - 240 V.AC. Check output at terminals 2 & 4; should measure 100 - 120 V.AC. Replace if defective.

Lamphouse Blowers Operate, but Power Supply Contactor Does Not Close

1. LAMP "ON" or MODE switch not set correctly. See Lamphouse Manual.
2. No voltage on terminals 5 & 6. Possible open interlock switch(s); see Lamphouse Manual.
3. Power supply overheated (open thermal switches). Check for correct blower operation and unobstructed air flow. Thermal switches will open if temperatures inside the power supply cabinet exceed 190° F. (88° C.).

Bulb Fails to Ignite; Blowers Operating, Contactor Closed

1. Check DC No Load output; should measure 120 - 140 V.DC. If lower, **consult factory.**
2. Faulty DC output connection. Check and tighten as required.
3. Blown fuse. **Allow power supply (5) minutes to discharge (power OFF) before removing the fuse.** Fuse should measure (0) Ohms. Replace as required.
4. Fuse blowing repeatedly. Loose DC connection; check and retighten. Burned cables on mother board; inspect and replace as required.

No Current Adjustment

1. Wires to adjustment potentiometer(s) broken. Resolder as required.
2. Defective mother board. **Consult factory.**

MAINTENANCE

The power supply requires very little service to insure correct operation. Periodically check all electrical connections for tightness and condition; discolored terminals may indicate oxidation which will increase resistance.

Clean the ventilation inlet and outlet grilles on a regular basis to insure good air flow. Thermal switches mounted to the power supply will interrupt operation of the power supply in the event of overheating.

The blower motors are permanently lubricated and require no oil.

220 VOLT CONTROL CIRCUITS

EARLY MODEL STRONG XENON LAMPHOUSES, including the X-16, X-25, and X-60, utilized a 220 V.AC control circuit to power the lamphouse blowers (if used) and the xenon bulb igniter. The currently manufactured Strong Switching Type Xenon Power Supply can be used with these systems when the installation wiring procedure outlined below is followed, and the 81819 Transformer is used.

1. Connect the heavy DC leads from the lamphouse to the DC output terminals in the xenon power supply. **Observe Correct Polarity;** RED to POSITIVE (+) and BLACK to NEGATIVE (-). Connect the system to an adequate earth ground.
2. Lamphouse control leads (2, 3, 4, 5, and 6) are supplied by the installer. Use 16 gauge (minimum) stranded copper wire with insulation suitable for 90° Celsius or higher, or a wire **conforming to local electrical codes**. Number the conductors, or if using colored wire, conform to Strong's color code:

2 - Brown	5 - Blue
3 - Red	6 - Yellow
4 - Orange	
3. Shield all leads in conduit or greenfield if desired, or if required by local electrical codes.
4. Wires 2 & 4 supply 220 V.AC to the lamphouse. Some models of switching power supplies (i.e. Type 62-84000) provide Terminals 7 & 8 adjacent to the DC output terminals to supply 220 V.AC. Use these terminals when present; otherwise connect lamphouse wires 2 & 4 to 220 V.AC derived from Terminals L1 and L3 on the power supply contactor (see INTERCONNECTIONS diagram).
5. Wires 5 & 6 return the control voltage from the lamphouse after all lamp interlock switches are closed. Route these wires to the lamphouse hook-up compartment in the power supply cabinet. Set the 81819 Stepdown Transformer supplied by Strong into the compartment. It need not be mounted if the power supply remains stationary.
6. Using the wire nuts provided, attach lamphouse wires 5 & 6 (220 V.) to the BLACK and GREEN primary leads of the 81819 stepdown transformer. Connect the two RED transformer secondary (115 V.) leads to Terminals 5 & 6 on the barrier strip adjacent to the DC output terminals in the power supply.
NOTE: Failure to use the stepdown transformer will damage the power supply.
7. Wires 3 & 6, where used, are supplied for automation switching. Do not apply voltage to these terminals; use a 5 ampere sustained dry contact. See the instructions furnished with the automation controller regarding LAMP control.
8. Apply AC power to the xenon power supply and set the DC output current as instructed in the INSTALLATION section of the Power Supply Instruction Manual.

INTERCONNECTIONS

Switching Power

Supply to: X-16

X-25

X-60

LAMPHOUSE (220 V.AC Control Circuit)

